



Purchase Date _____
Model # _____
Serial # _____

PROOF/HOLD CABINET HEAT UNIT

**Model: H-HEAT UNIT-EXT-6
H-HEAT UNIT-EXT
H-HEAT UNIT-INT
H-HEAT UNIT-74**

Warranty Service Hotline: 855-807-2638
Non-Warranty Replacement Parts: 877-556-3645
Monday - Friday 8:30am - 5:00pm EST

Lockwood Manufacturing
31251 Industrial Road
Livonia, MI 48150
www.lockwoodusa.com
customerservice@lockwoodusa.com



READ THOROUGHLY BEFORE OPERATING OPERATIONS / MAINTENANCE INSTRUCTIONS

Lockwood would like to thank you for the purchase of your new proof/hold cabinet. We take pride in our equipment designs and quality manufacturing which has been in operation for over 50 years at our facility in Southeast Michigan. Please make note of your model and serial number which can be found on the front face plate of your heat unit and then visit our website to register and validate your warranty.

All food service equipment should be operated by trained personnel. This cabinet is designed to hold the temperature of heated foods. It is not intended to heat cold foods. **Never operate the cabinet unattended.** Insulated cabinets will hold temperatures to approximately 185° F +/- 10° F; non-insulated cabinets will hold to approximately 160° F +/- 10° F. Proofing temperatures will be lower. If temperatures exceed 200° F, cease use and seek assistance. Temperatures inside the cabinet can be affected by one or more of the following conditions: Temperature of product(s) placed inside of cabinet; Surrounding ambient air temperature; how often the cabinet door is opened and closed.

Installation

1. Place cabinet in a warm area away from ventilation or cold drafts for best performance.
2. Remove all plastic protective covering and wipe down to remove any dust or dirt before first use.
3. Plug three prong power cord into a single 120V, 15 amp **dedicated** circuit (minimum). Avoid GFI outlets when possible.
4. Install runners if applicable (CA39, CA71, CA72, CA73, CA74)
5. Review instructions for both modes of operation below and allow the heat unit to run in HOLD mode for at least 1 hour before proofing or holding food after initial start up.

Proof Mode Instructions

ALLOW A MINIMUM OF 45 MINUTES TO REACH DESIRED TEMPERATURE.

1. Fill the 4.3 quart water pan located on top of the heat unit with **DISTILLED WATER**. Element should be totally submerged at all times. Tap water may contain various minerals that will leave residue on the immersible element which reduces the heating capability.
2. Push the “ON / OFF” switch to the “ON” position. Red indicator light will illuminate.
3. Pre-heat the cabinet. Push the “PROOF / HOLD” switch to the “HOLD” position. This will activate the two dry heat elements (500 W & 1000 W) inside the heat unit.
4. Set the thermostat control (marked Temperature) to 7 or 8 to quickly heat the cabinet.
5. Upon the temperature reaching around your desired temp, push the “PROOF / HOLD” switch to the “PROOF” position.
6. Turn the temperature dial down slightly (indicator light should stay on) and the humidity dial to 7 or 8. The 1000 watt element in the water pan is now activated and the water can become very hot. **WARNING - DO NOT TOUCH THE WATER!** The 500 watt internal dry heat element is also in use while in “PROOF” mode.
7. Turn both the temperature and humidity dials to the appropriate levels for your particular use. Setting the humidity too high, may cause excess water to condense and run down the interior of the cabinet and drain from the cabinet.
8. Place the “ON / OFF” switch in the “OFF” position when heat unit is not in use.

NOTE: Never place frozen dough in the proof cabinet. Different types of dough will require different conditions to proof. The above directions are only guidelines on starting the heat unit and are not designed as a standard for proofing products. There will be some trial and error before you reach the heat and humidity levels appropriate for your products.

Hold Mode Instructions

ALLOW A MINIMUM OF 45 MINUTES TO REACH DESIRED TEMPERATURE

1. Push the “ON / OFF” switch to the “ON” position. Red indicator light will illuminate while the cabinet is heating up.
2. Push the “PROOF / HOLD” switch to the “HOLD” position. This will activate the two dry heat elements (500 W & 1000 W) inside the heat unit.
3. Set the thermostat control (marked Temperature) to 7 or 8 in the beginning to heat cabinet quickly. Then adjust to your desired temperature based on digital thermometer reading, located on the front panel of heat unit, if equipped. Monitor your operations, cabinet holding temperature, and food temperatures periodically during use to ensure you are achieving the desired results.
4. Place the “ON / OFF” switch in the “OFF” position when heat unit is not in use.

NOTE: When unit is in “HOLD” mode the element in the water pan does not activate.





Maintenance

MAKE CERTAIN THAT THE CABINET HAS COOLED DOWN AND IS UN-PLUGGED FROM ELECTRICAL SOURCE BEFORE CLEANING.

1. All aluminum parts of the cabinet can be washed down with a mild detergent and water. Abrasive cleaners should not be used. Any Lexan (polycarbonate) surfaces should **NOT** be cleaned with any ammonia based product.
2. The heat unit can be removed from the cabinet by removing the thumb screws. (One thumb screw on each side of unit.)
3. The water pan and immersible element can become coated with mineral deposits that will adversely affect their operation. Distilled water lessens this occurrence. De-scale or de-lime with equal amounts of white vinegar and baking soda and a medium to soft bristle brush to scrub the surfaces. Rinse thoroughly to eliminate transfer of cleaning odors to food. A weekly cleaning is recommended.

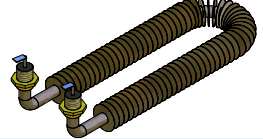
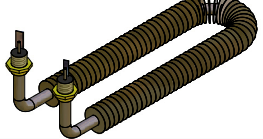
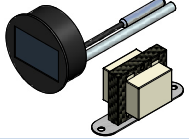
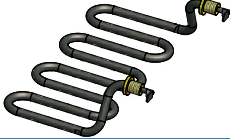
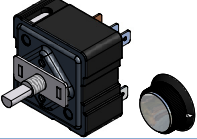
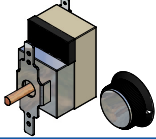
**FOR ADDITIONAL HELP AND FAQ - www.lockwoodusa.com (click on SUPPORT tab)
TO REGISTER YOUR HEAT UNIT WARRANTY - www.lockwoodusa.com/warranty**

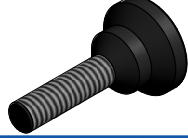
PARTS LIST

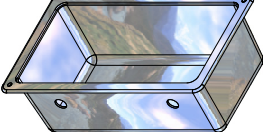
	Control Dial (1) (H-DIAL)		500 Watt Internal Element (H-ELEMENT-500)
	On/Off & Proof/Hold Switch (Includes Switch Guard) (H-SW-ON/OFF) (H-SW-P/H)		1000 Watt Internal Element (H-ELEMENT-1000)
	Digital Thermometer w/ transformer (H-THERM-DIGITAL) (except CA73)		1000 Watt Immersible Element (H-ELEMENT-IE)
	Humidity Control (dial included) (H-HUMIDITY)		Blower Motor (H-BLOWER)
	Temperature Control (dial included) (H-THERMOSTAT)		Terminal Block (H-TBLOCK-A)
	Cord Holder (H-CAP)		9' Electrical Cord (H-CORD)
	Plastic Foot (H-FOOT)		Thumb Screw (2/set) (H-KNOB) - (except CA73)
Magnetic Latch Door Handle (HAN-CA-V02)			Indicator Pen Lights (3/set) (H-IDL)
Replacement Non-magnetic Door Gasket (sold by the foot) (DOOR GASKET)			Water Pan - 4.3 Quart (H-WATER PAN-S) approx. dims 6"W x 12"L x 4"D

WARRANTY

Heat units are under warranty for one year after purchase, including parts, labor and freight. The warranty does not apply to heat units that have been subject to neglect, alteration, misuse or accident. The warranty seal must not be broken or the warranty will be void. Lockwood Manufacturing does not assume or authorize any other person or company to undertake any liability with Lockwood merchandise without prior written authorization.

For warranty service, please have your serial number ready and contact 855-807-2638, Monday - Friday, 8:30am - 5pm EST.

If the heat unit is no longer under warranty, parts are available for purchase
Heritage Parts (877) 556-3645, www.heritageparts.com

If you have questions regarding your heat unit and the warranty please feel free to contact Lockwood Manufacturing for clarification. Thank you for your purchase. Don't forget to go online and register your heat unit at: www.lockwoodusa.com/warranty

WIRING DIAGRAM

HEAT UNIT WIRE DIAGRAM



For Models:
H-HEAT UNIT-EXT * H-HEAT UNIT-EXT-6 * H-HEAT UNIT-74 * H-HEAT UNIT-INT
Manufactured after 12/01/2016

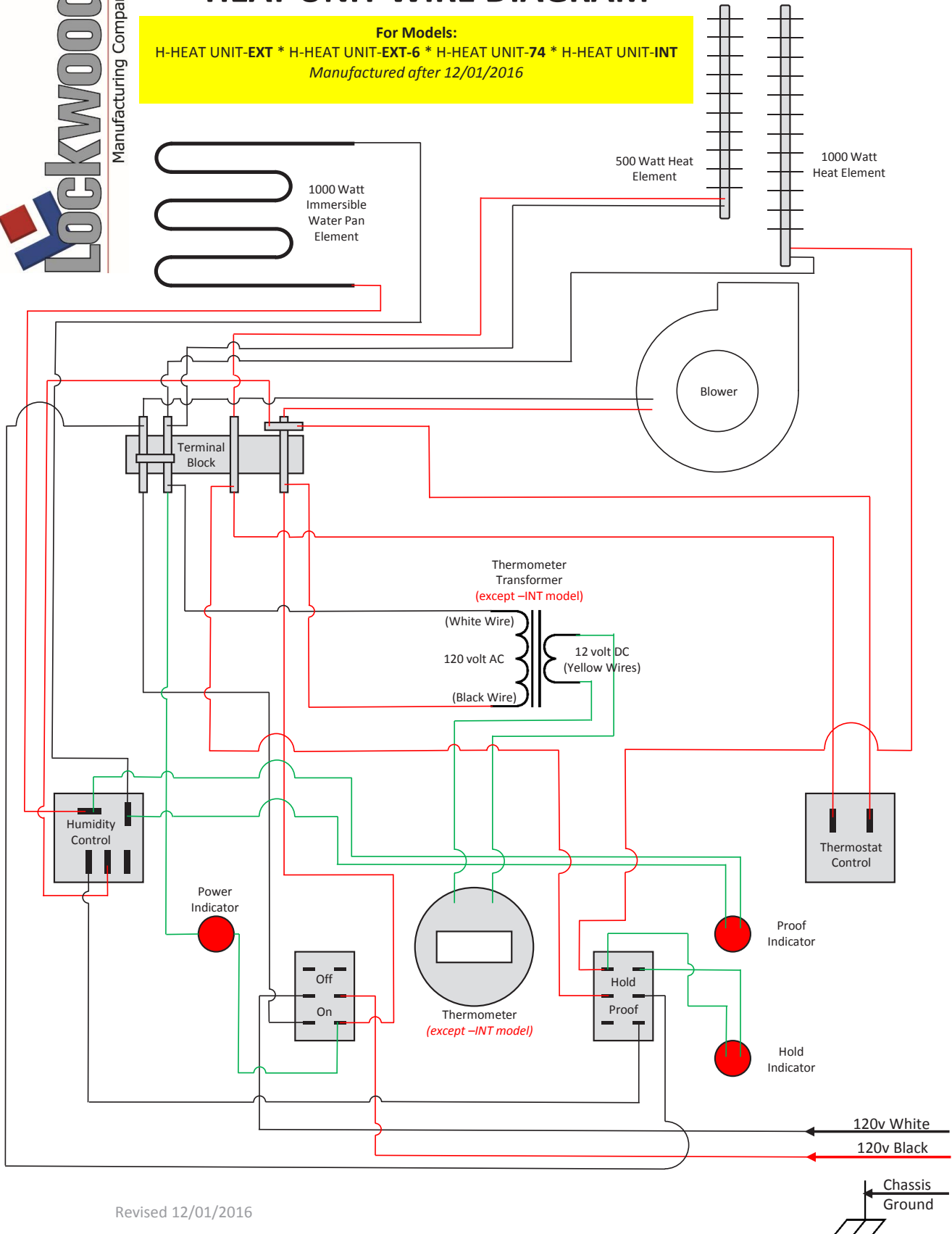

Revised 12/01/2016